

DSECONTROL[®] MONITORING WITH INTELLIGENCE.



DSE5310 & DSE5320

AUTO START & AUTO MAINS FAILURE CONTROL MODULES (ELECTRONIC ENGINE ENABLED)

DSE5310



DSE5320



The DSE5310 is an Automatic Start Control Module designed to automatically start and stop diesel and gas generating sets that include non electronic and electronic engines. The module also provides advanced engine monitoring and protection features.

The module has the ability to monitor under speed, over speed, charge failure, emergency stop, low oil pressure, high engine temperature, fail to start, fail to stop, under/over generator volts, over current, under/over generator frequency, low/high DC battery volts, low fuel alarm and loss of the speed sensing signal. The module displays fault conditions on the LCD display and via the LED indicators on the front.

The DSE5320 is an Automatic Mains (utility) Failure Control Module and includes all the features of the DSE5310 plus the ability to monitor a mains (utility) supply. Upon detection of a mains (utility) failure the module automatically starts the generating set. Once the mains (utility) power has been restored the module instructs the generating set to stop.

Both modules include RS232 and RS485 communication capabilities for linking to a PC, sending SMS messages and interfacing with new and existing building management systems.

FEATURES

- Automatic start
- Automatic load transfer
- Automatic mains (utility) failure
- Electronic engine connection
- RS232 and RS485 remote communications
- Modbus RTU
- Analogue inputs
- Audible alarm indication
- Back-lit character & 4-line text LCD display
- Configurable alarms & timers
- Configurable auxiliary inputs
- Digital inputs
- Emergency stop functions
- Engine history event log
- Engine exercise mode
- Engine protection
- Front panel mounting
- Front panel programming
- Full engine diagnostics
- Generator operating status warning
- LCD alarm indication
- LED alarm indication
- Manual start
- Multiple language options
- PC configurable
- PIN protected programming
- Power save mode
- Remote monitoring
- SMS messaging

BENEFITS

- Full integration into new & existing building management systems
- Full engine protection & instrumentation without the need for additional senders (Electronic engines only)
- In-built engine diagnostics removes the requirement for service equipment

- License free PC software
- Remote module control and monitoring using comprehensive DSE PC software
- Modules improve the life cycle of engine starter motors
- On-site and remote module configuration
- Modules send SMS messages to engineers to notify specific engine problems (GSM Modem and SIM Card required)
- User-friendly set-up and button layout

OPERATION

The modules are operated using the front STOP, AUTO and MANUAL push buttons. The DSE5320 also includes a TEST button. An additional push button allows the user to scroll through the LCD display.

CONFIGURATION

The modules can be configured using the front panel buttons or the DSE810 interface and PC software.

SPECIFICATION

DC SUPPLY
8 V to 35 V continuous

CRANKING DROPOUTS
Able to survive 0V for 50mS, providing the supply was at least 10V before dropout and supply recovers to 5V

AUXILIARY OUTPUTS 1-3
5A DC at supply voltage

AUXILIARY OUTPUTS 4 & 5
(DSE5320 only)
8 A AC rated volt-free relay

MAXIMUM OPERATING CURRENT
400mA at 12V, 200mA at 24V

STANDBY CURRENT
(when in auto)
230mA at 12V, 120mA at 24V

SLEEP MODE CURRENT
70mA at 12V, 45mA at 24V

MODULE DIMENSIONS (WxH)
240mm x 172mm
9.4" x 6.8"

PANEL CUT-OUT (WxH)
220mm x 160mm
8.7" x 6.3"

MAXIMUM PANEL THICKNESS
8mm
0.3"

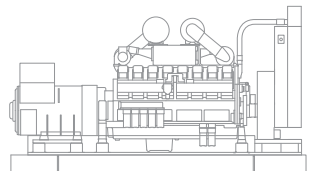

ELECTRONIC ENGINE CAPABILITY

ENVIRONMENTAL TESTING STANDARDS

ELECTRO MAGNETIC CAPABILITY (EMC)

BS EN 61000-6-4
EMC Generic Emission Standard for the Industrial Environment
BS EN 61000-6-2
EMC Generic Immunity Standard for the industrial environment

ELECTRICAL SAFETY

BS EN 60950
Safety of information technology equipment including electrical business equipment

TEMPERATURE

BS EN 60068-2-2
Test Ab to 70°C
Test Ab to -30°C

VIBRATION

BS EN 60068-2-6
Ten sweeps in each of the three major axes
5Hz to 8Hz @ +/- 7.5mm

HUMIDITY

BS EN 60068-2-30
Test Db 95% RH @ 550C for 12 hours

SHOCK

BS EN 60068-2-27
Three shocks in each of three major axes
15gn In 11ms

COMMUNICATIONS

The DSE5310 & DSE5320 have a number of different communication capabilities.

SMS Messaging

When the module detects an alarm condition, it has the ability to send an SMS message to a dedicated mobile number, notifying an engineer of the problem. (GSM Modem and SIM Card required)

Remote Communications

When the module detects an alarm condition, it dials out to a PC notifying the user of the exact alarm condition.

Building Management

The module has been designed to be integrated into new and existing building management systems.

PC Software

The module has the ability to be configured and monitored from a remote PC, using the DSE810 interface.

EVENT LOG

The module includes a comprehensive event log that shows the 30 most recent alarm conditions and the date and time that they occurred. This function assists the user when fault finding and maintaining a generating set.

INSTRUMENTATION

The modules provide advanced metering facilities, displaying the information on the LCD display. The information can be accessed using the display scroll push buttons located next to the LCD display.

EXPANSION MODULE COMPATIBILITY

DSE157 Relay Input Expansion Module
DSE545 & DSE 548 Remote Annunciation Expansion Module
DSE130 Input Expansion Module

ELECTRONIC ENGINE COMPATABILITY

- Cummins
- Deutz
- John Deere
- MTU
- Perkins
- Scania
- Volvo
- Generic
- Plus additional manufacturers

5310	5320
Generator Instruments Volts, Hz, Amps, kW, kVA, Pf,Kwh, kVAh, kVAh, KVAh	Generator Instruments Volts, Hz, Amps, kW, kVA, Pf,Kwh, kVAh, kVAh, KVAh
Engine Instruments RPM, Oil Pressure, Coolant Temperature, Hours Run, Charging Voltage, Battery Volts.	Engine Instruments RPM, Oil Pressure, Coolant Temperature, Hours Run, Charging Voltage, Battery Volts.
Electronic Engines Enhanced Instrumentation and Engine ECU diagnostics via electronic engine interface.	Electronic Engines Enhanced instrumentation and Engine ECU diagnostics via electronic engine interface.
	Mains/Utility Instruments Volts, Frequency, Amps (optional when CT's are fitted load side of the line)

RELATED MATERIALS

TITLE	PART NO'S
DSE5310 Installation Instructions	053-012
DSE5320 Installation Instructions	053-014
DSE5310 Manual	057-013
DSE5320 Manual	057-014
DSE157 Data Sheet	055-045
DSE545 & DSE548 Data Sheet	055-049
DSE130 Data Sheet	055-047
52/53xx Software Manual	057-006
CAN & DSE wiring guide	057-004

DSE5310 & DSE5320

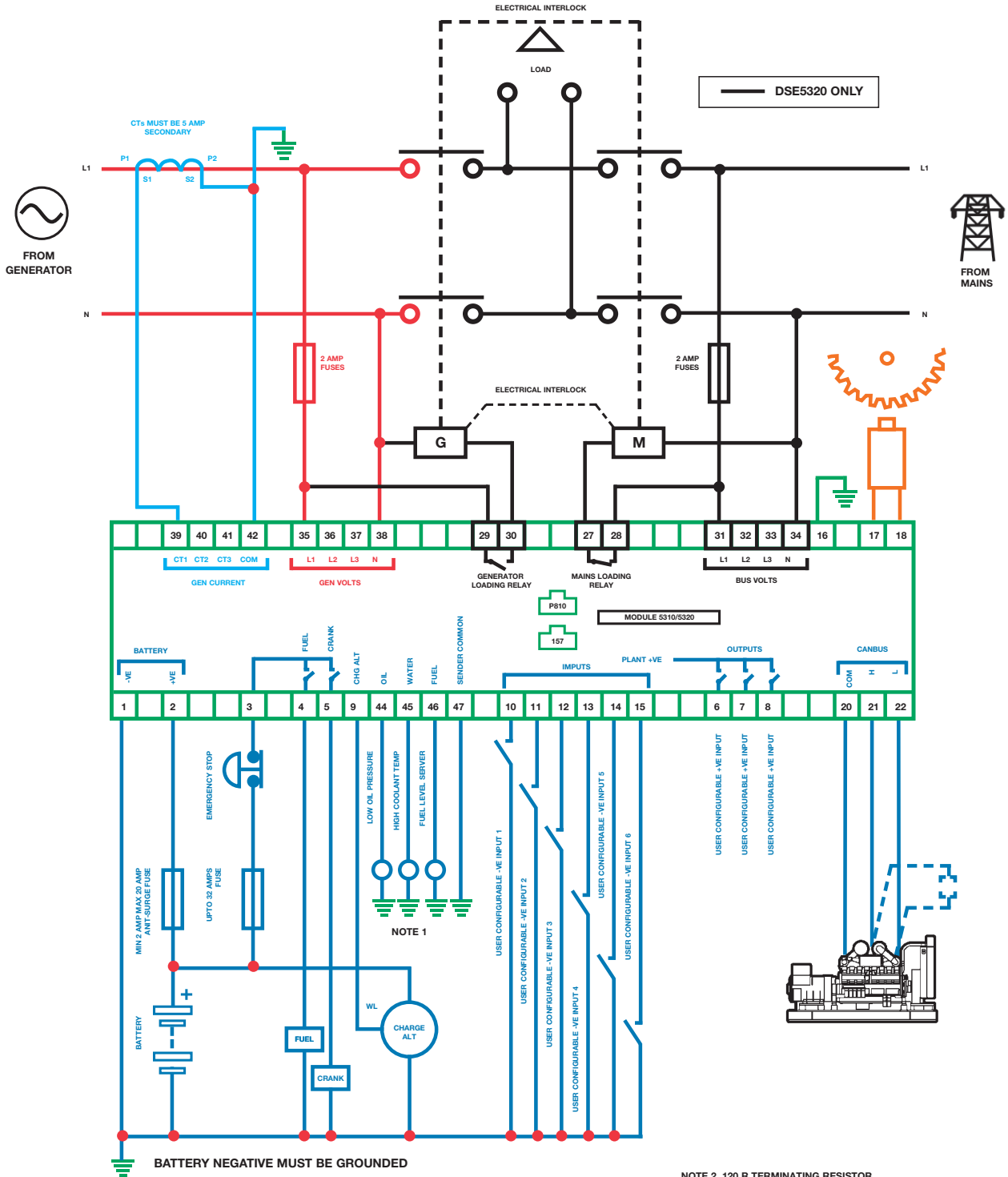

BATTERY NEGATIVE MUST BE GROUNDED

TERMINALS SUITABLE FOR 22-16 AWG (0.6mm - 1.3mm) FIELD WIRING

TIGHTENING TORQUE = 0.8Nm (7lb-in)

NOTE 1

THESE GROUND CONNECTIONS MUST BE ON THE ENGINE BLOCK, AND MUST BE TO THE SENDER BODIES. THE GROUND WIRE TO TERMINAL 47 MUST NOT BE USED TO PROVIDE A GROUND CONNECTION TO ANY OTHER DEVICE

NOTE 2. 120 R TERMINATING RESISTOR MAY BE REQUIRED EXTERNALLY SEE ENGINE MANUFACTURERS LITERATURE

DEEP SEA ELECTRONICS PLC

Highfield House
 Hunmanby Industrial Estate
 Hunmanby, North Yorkshire
 YO14 0PH England

TELEPHONE

+44 (0)1723 890099

FACSIMILE

+44 (0)1723 893303

EMAIL

sales@deepseapl.com

WEBSITE

www.deepseapl.com



Registered in England & Wales No.01319649

VAT No.316923457

DEEP SEA ELECTRONICS PLC THAILAND

TPI Tower, Lobby 3
 Floor 27, 26-56 Chan New Road
 Tungmahamek, Sathom
 Bangkok 10120, Thailand

TELEPHONE

+66 (0) 2678 3028

FACSIMILE

+66 (0) 2670 6228

EMAIL

sales@dsepl.com

WEBSITE

www.deepseapl.com

DEEP SEA ELECTRONICS INC USA

3230 Williams Avenue
 Rockford
 IL 61101-2668 USA

TELEPHONE

+1 (815) 316 8706

FACSIMILE

+1 (815) 316 8708

EMAIL

sales@deepseausa.com

WEBSITE

www.deepseausa.com

YOUR LOCAL DISTRIBUTOR.

DEEP SEA ELECTRONICS PLC maintains a policy of continuous development and reserves the right to change the details shown on this data sheet without prior notice. The contents are intended for guidance only.

This data sheet is printed on 9lives 55 Silk, which is produced with 55% recycled fibre from both pre and post-consumer sources, together with 45% virgin ECF fibre.

