

DSEPOWER® SHARING WITH SIMPLICITY.

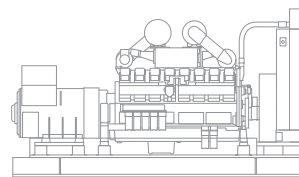

DSE5520

AUTO MAINS FAILURE & INSTRUMENTATION CONTROL MODULE (ELECTRONIC ENGINE ENABLED)



ELECTRONIC ENGINE CAPABILITY

The DSE5520 is an Automatic Mains Failure Control Module designed to provide advanced load share functionality for diesel and gas generating sets that include non electronic and electronic engines. The module also provides excellent engine monitoring and protection features.

The module monitors the mains (utility) supply and upon detection of a loss in power automatically starts the generating set.

The modules synchronising functions include automatic synchronising with built in synchroscope and closing onto dead bus. Direct and flexible outputs from the module are provided to allow connection to the most commonly used speed governors and automatic voltage regulators (AVR's). The module has been designed to combine a maximum of 16 generators and 16 mains (utility) supplies up to a maximum of 20 in one system, e.g. 16 generators and 4 mains (utility) supplies (DSE5560 required to synchronise with the mains).

The module has the ability to monitor under/over generator volts, over current, under/over generator frequency, under speed, over speed, charge fail, emergency stop, low oil pressure, high engine

temperature, fail to start, low/high DC battery volts, fail to stop, generator short circuit protection, reverse power, generator phase rotation error, earth fault protection, loss of speed signal, fail to open, fail to close, out of sync, MPU open circuit failure, negative phase sequence and loss of excitation.

FEATURES

- Electronic engine capability
- RS232 and RS485 remote communications
- Modbus RTU
- Pin number protected front panel programming
- Engine exercise timer
- Back-lit LCD 4-line text display
- Multiple language options
- Voltage measurement
- Configurable inputs (9)
- Configurable outputs (5)
- Automatic start
- Manual start
- Audible alarm
- LED indicators
- Built-in governor and AVR control for easy operation and panel engineering
- Engine history event log
- Engine protection
- Fault condition notification to a designated PC
- Front panel mounting
- PC configuration
- Mains (utility) failure detection
- Configurable alarm timers
- Configurable start & stop timers
- Automatic load transfer
- SMS alert messaging

- Multi set communications
- Front panel mounting
- Remote control and monitoring

LOAD SHARE FEATURES

- ROCOF & vector shift
- Automatic starting & stopping of generator on load demand
- Dead bus sensing
- Module has the ability to interface with existing load share lines
- Direct communication from the module to the governor and AVR
- Link up to 16 generators
- Volts & frequency matching
- KW and Kvar load sharing with multiple generators

BENEFITS

- Sends SMS messages to engineers to notify specific engine problems (GSM Modem and SIM card required)
- On-site and remote module configuration
- In-built engine diagnostics removes the requirement for service equipment
- Full engine protection & instrumentation without the need for additional senders (Electronic engines only)
- Remote monitoring of the module using comprehensive DSE PC software
- License free PC software

SPECIFICATION

DC SUPPLY

8V to 35V continuous

CRANKING DROPOUTS

Able to survive 0V for 50mS, providing supply was at least 10V before dropout and supply recovers to 5V. This is achieved without the need for internal batteries

MAXIMUM OPERATING CURRENT

460mA at 12V. 245mA at 24V

MAXIMUM STANDBY CURRENT

375mA at 12V. 200mA at 24V

ALTERNATOR INPUT RANGE

15V(L-N) to 333V AC (L-N) absolute maximum

ALTERNATOR INPUT FREQUENCY

50Hz - 60Hz at rated engine speed (Minimum: 15V AC L-N)

MAGNETIC PICK-UP VOLTAGE RANGE

+/- 0.5V to 70V Peak

MAGNETIC INPUT FREQUENCY

10,000 Hz (max)

MAINS SENSING RANGE

15V(L-N) to 333V AC (L-N) absolute maximum

MAINS SENSING INPUT FREQUENCY

50Hz-60Hz (Minimum: 15V AC L-N)

START RELAY OUTPUT

16A DC at supply voltage

FUEL RELAY OUTPUT

16A DC at supply voltage

AUXILIARY RELAY OUTPUTS

Three outputs 5 Amp DC at supply voltage
Two outputs volt free 8 Amp at 250V AC

GENERATOR LOADING RELAY OUTPUT

8A AC 250V

MAINS LOADING RELAY OUTPUT

8A AC 250V

CHARGE FAIL/EXCITATION RANGE

0V to 35V

BUILT-IN GOVERNOR AND AVR CONTROL

Fully Isolated
Minimum Load Impedance:
1000Ω
Gain Volts: 0V-10V DC
Offset Volts: +/- 10V DC

DIMENSIONS

240mm x 172mm x 57mm
9.4" x 6.8" x 2.2"

PANEL CUTOUT

220mm x 160mm
8.7" x 6.3"

ENCLOSURE PROTECTION

IP55 (with optional gasket)
IP42 (without gasket)

ENVIRONMENTAL TESTING STANDARDS

ELECTRO MAGNETIC COMPATIBILITY (EMC)

BS EN 50081-2 EMC Emission
Standard for the Industrial Environment

ELECTRICAL SAFETY

BS EN 60950 Low Voltage Directive/Safety of Information Technology Equipment, including Electrical Business Equipment

TEMPERATURE

COLD

BS EN 60068-2-1 to -30°C

HOT

BS EN 60068-2-2 to 70°C

BS EN 50082-2 EMC IMMUNITY

Standard for the Industrial Environment

VIBRATION

BS EN 60068-2-6 Ten sweeps (up and back down) at 1 octave/minute in each of the three major axes

5Hz to 8Hz @ +/-7.5mm constant displacement

8Hz to 500Hz @2gn constant acceleration

HUMIDITY

BS EN 2011 part 2.1 93% RH @ 40°C for 48 hours

SHOCK

BS EN 60068-2-27 Three half sine shocks in each of the three major axes 15gn amplitude 11ms duration

TYPICAL LOAD SHARE APPLICATION

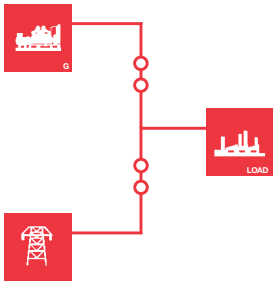

OPERATION

The module is operated using the front STOP/RESET, MANUAL, AUTO and START pushbuttons. Three of these push buttons include an LED indicator. Additional pushbuttons provide LCD display scroll, lamp test, mute functionality and breaker control.

BUILT-IN FUNCTIONS

- Alternator under/over volts
- Alternator under/over frequency
- Warning or shutdown on engine temperature, over/under speed, oil pressure
- Warning, shutdown or electrical trip on battery volts or over current
- Shutdown or electrical trip on reverse power, phase rotation or short circuit fault
- Earth fault shutdown
- Adjustable crank cycle/attempts
- Full remote control and telemetry
- 9 configurable digital inputs
- 5 configurable and 2 fixed relay outputs
- System lock input
- Load switching control push-button inputs
- Restricted access to programming via PIN number
- Loss of excitation
- Negative phase sequence
- ROCOF/vector shift (mains (utility) decoupling)
- Peak lopping
- Peak shaving
- Mains (utility) reverse power

INSTRUMENTATION AND ALARMS

The DSE5520 module provides advanced metering and alarm functionality via the LCD display. The information can be accessed using the display scroll pushbuttons. The table below shows the instrumentation and alarm features the module provides.

Engine Speed
Engine Oil Pressure
Coolant Temperature
Battery Voltage
Charge Alt Volts
Engine Run Time
Number of Starts
Additional instrumentation as provided by the electronic ECU
Next Maintenance (if enabled)
Fuel Level
Generator Volts (L-N)
Generator Volts (L-L) Gen Hz
Generator Amps
Generator Earth Current
Generator kW (L1,L2,L3)
Generator Total kW
Generator pf (L1,L2,L3)
Generator Average pf
Generator Total kVAr
Generator kWh
Generator kVAh
Generator kVAh
Generator Phase Sequence
Synchroscope
Mains (utility) Volts (L- N)
Mains (utility)Volts (L-L)
Mains (utility)Hz
Mains (utility)Amps
Mains (utility)kW
Mains (utility)kVA
Mains (utility)pf
Mains (utility)kVAh
Mains (utility)Phase Sequence
Generator kVA

TELEMETRY

The module gives the user full telemetry facilities when using the optional communications software. The module can be connected to a PC using the DSE810 PC interface or by using a suitable modem.

The PC software is Microsoft Windows based. All access into the module can be configured to become password protected to prevent unauthorised entry. The PC software allows the module to be controlled from a remote location.

COMMUNICATIONS

The DSE5520 has a number of different communication capabilities.

SMS Messaging

When the module detects an alarm condition, it has the ability to send an SMS message to a dedicated mobile number, notifying an engineer of the problem. (GSM Modem and SIM Card required).

Remote Communications

When the module detects an alarm condition, it dials out to a PC notifying the user of the exact alarm condition.

Building Management

The module has been designed to be integrated into new and existing building management systems.

PC Software

The module has the ability to be controlled, configured and monitored from a remote PC, using the DSE810 interface.

EVENT LOG

The module includes a comprehensive event log that shows the 25 most recent alarm conditions and the date and time that they occurred. This function assists the user when fault finding and maintaining a generating set.

EXPANSION MODULES

DSE157 Relay Input
Expansion Module
DSE545 & DSE548 Remote
Annunciation Expansion Module
DSE130 Input Expansion Module

DSE5520

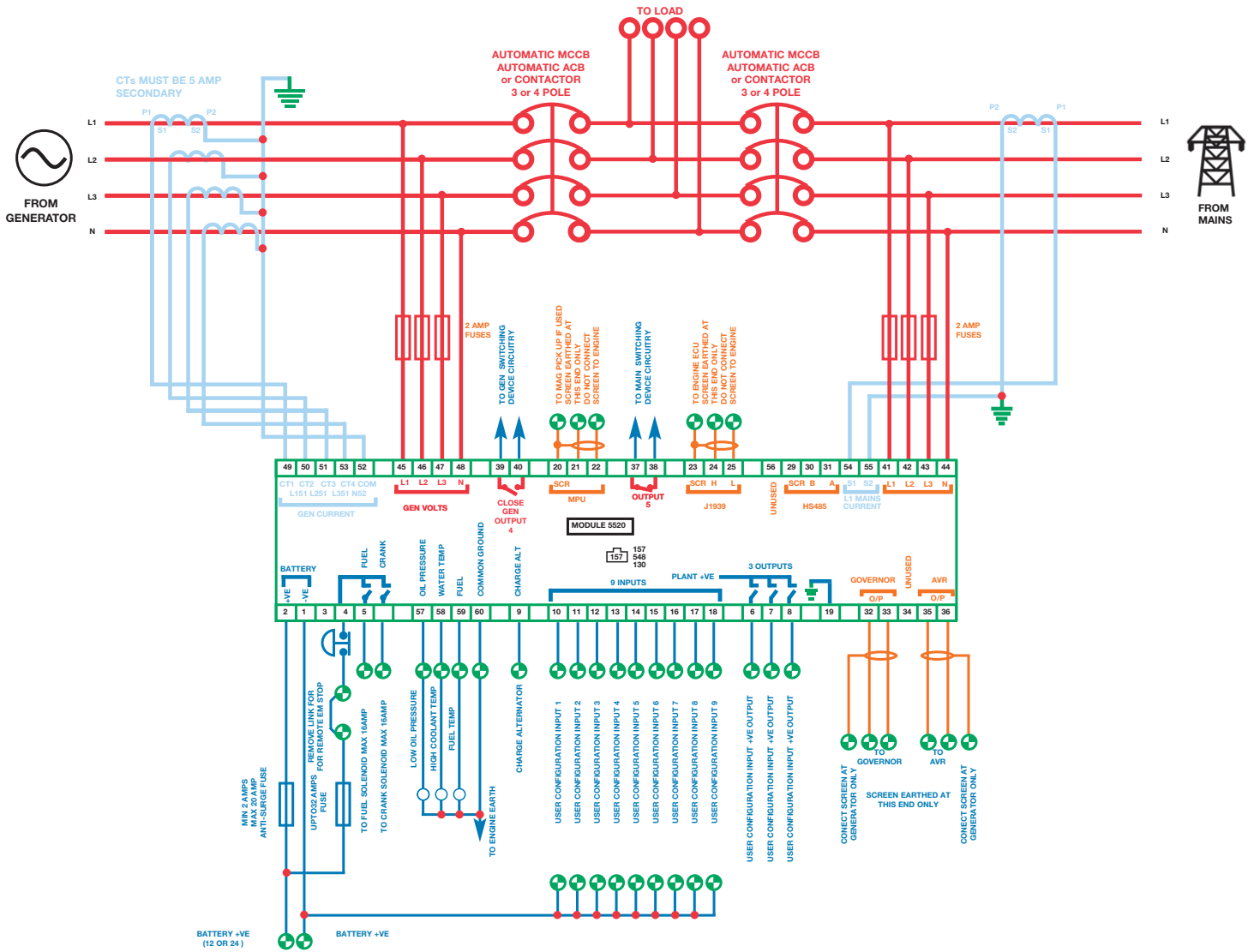

ELECTRONIC ENGINE COMPATIBILITY

- Cummins
- Deutz
- John Deere
- MTU
- Perkins
- Scania
- Volvo
- Generic
- Plus additional manufacturers

RELATED MATERIALS

TITLE	PART NO'S
DSE5520 Manual	057-016
DSE810 Manual	057-052
Guide to Synchronising and Load Sharing	057-045/6
55xx Software manual	057-007
CAN & DSE wiring guide	057-004
Load Share Design & Commissioning	057-047

DEEP SEA ELECTRONICS PLC

Highfield House
 Hunmanby Industrial Estate
 Hunmanby, North Yorkshire
 YO14 0PH England

TELEPHONE

+44 (0)1723 890099

FACSIMILE

+44 (0)1723 893303

EMAIL

sales@deepseapl.com

WEBSITE

www.deepseapl.com



Registered in England & Wales No.01319649

VAT No.316923457

DEEP SEA ELECTRONICS PLC THAILAND

TPI Tower, Lobby 3
 Floor 27, 26-56 Chan New Road
 Tungmahamek, Sathom
 Bangkok 10120, Thailand

TELEPHONE

+66 (0) 2678 3028

FACSIMILE

+66 (0) 2670 6228

EMAIL

sales@dsepl.com

WEBSITE

www.deepseapl.com

DEEP SEA ELECTRONICS INC USA

3230 Williams Avenue
 Rockford
 IL 61101-2668 USA

TELEPHONE

+1 (815) 316 8706

FACSIMILE

+1 (815) 316 8708

EMAIL

sales@deepseausa.com

WEBSITE

www.deepseausa.com

YOUR LOCAL DISTRIBUTOR.

DEEP SEA ELECTRONICS PLC maintains a policy of continuous development and reserves the right to change the details shown on this data sheet without prior notice. The contents are intended for guidance only.

This data sheet is printed on 9lives 55 Silk, which is produced with 55% recycled fibre from both pre and post-consumer sources, together with 45% virgin ECF fibre.

